

**NOTES:**

- ① FINISH GRADE.
- ② TOPSOIL BACKFILL, NO PARTICLES GREATER THAN 1". COMPACT PER SPECIFICATIONS.
- ③ SIX INCHES SAND FILL COVER, ABOVE MAINLINE.
- ④ PVC PIPE LATERAL.
- ⑤ ELECTRIC WIRES IN 2" SCHEDULE 40 ELECTRICAL CONDUIT FROM CONTROLLER TO VALVE.
- ⑥ 6" UNLESS OTHERWISE NOTED.
- ⑦ 2" FROM BOTTOM OF TRENCH.
- ⑧ LATERAL - 12" MIN. COVER.
- ⑨ MAINLINE - 24" MIN. COVER.
- ⑩ 2" MINIMUM SEPARATION.
- ⑪ PVC PIPE MAINLINE.
- ⑫ SIDES OF TRENCH WILL BE DUG SQUARE AND BE CLEAN OF ALL SHARP MATERIAL.

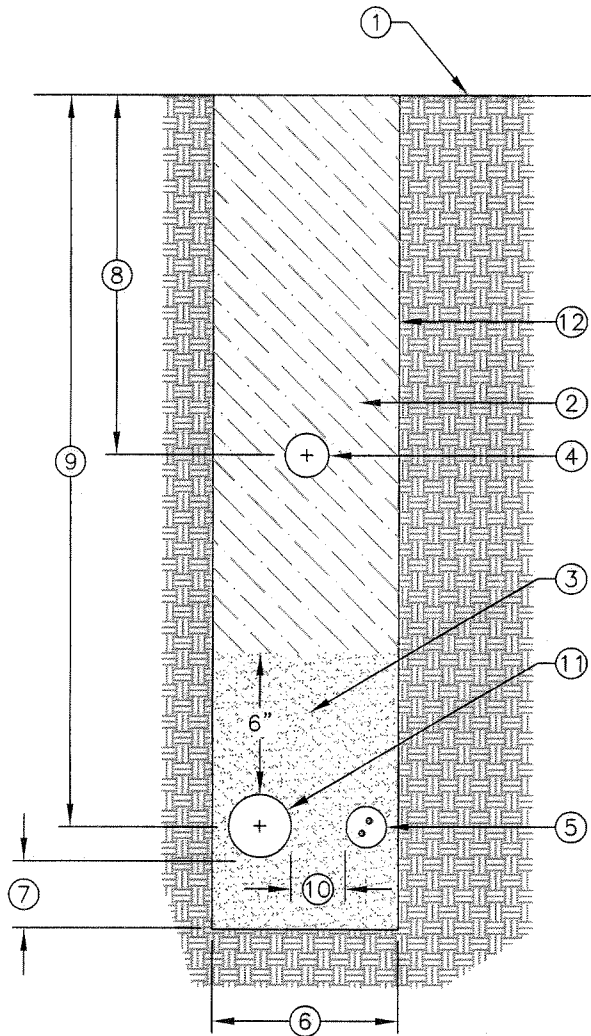

**SECTION VIEW**

REVISION	BY	DATE	APP. BY	COUNCIL

**CITY OF CHICO**

**STANDARD PLAN**

DRAWN BY: GL DATE: 10/06

CHECKED BY: DB SCALE: NONE

APPROVED: [Signature]  
DIRECTOR OF ENGINEERING

**TRENCHING DETAIL**

NO.  
**LS-14**

SHEET 1 OF 3

**NOTES:**

- ① FINISH GRADE.
- ② PAVING.
- ③ SIX INCHES SAND FILL COVER, ABOVE TOP PIPE.
- ④ PVC PIPE LATERAL.
- ⑤ ELECTRIC WIRES IN 2" SCHEDULE 40 ELECTRICAL CONDUIT FROM CONTROLLER TO VALVE.
- ⑥ 6" UNLESS OTHERWISE NOTED.
- ⑦ 2" FROM BOTTOM OF TRENCH.
- ⑧ SLEEVING - 26" BENEATH PAVING, MINIMUM SIZE: 4" OR AS REQUIRED.
- ⑨ NATIVE SOIL COMPACTED TO 95%.
- ⑩ PVC PIPE MAINLINE.
- ⑪ SIDES OF TRENCH WILL BE DUG SQUARE AND BE CLEAN OF ALL SHARP MATERIAL.

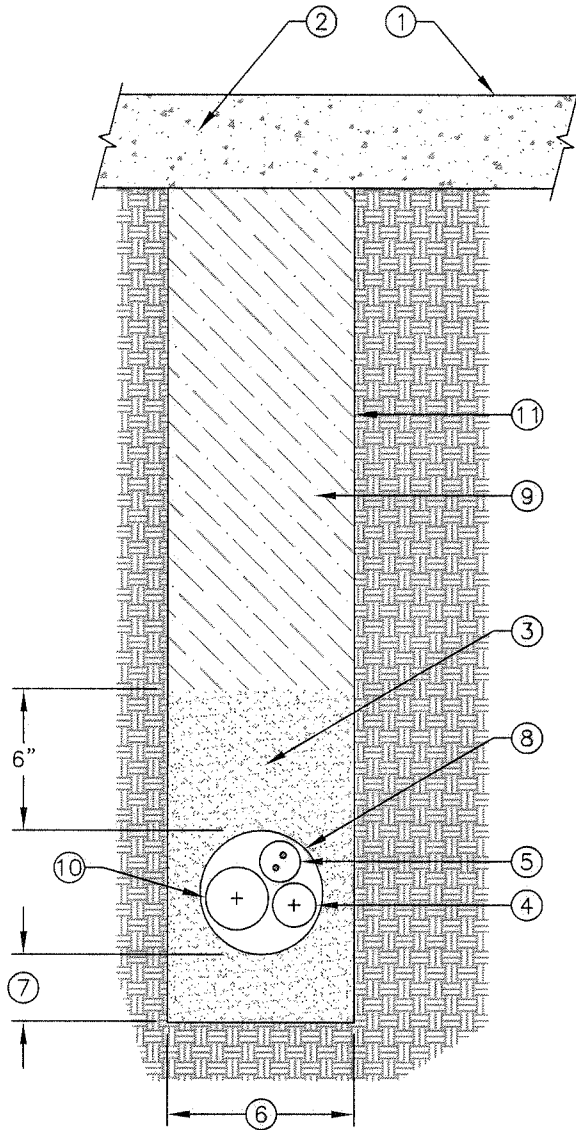

**SECTION VIEW**

REVISION	BY	DATE	APP. BY COUNCIL

**CITY OF CHICO**

**STANDARD PLAN**

DRAWN BY: GL      DATE: 10/06  
 CHECKED BY: DB      SCALE: NONE  
 APPROVED: [Signature]  
 DIRECTOR OF ENGINEERING

**TRENCHING DETAIL  
 BENEATH PAVING  
 (NON-VEHICULAR)**

NO.  
**LS-14**  
 SHEET 2 OF 3

**NOTES:**

- ① FINISH GRADE.
- ② PAVING.
- ③ SIX INCHES SAND FILL COVER, ABOVE TOP PIPE.
- ④ PVC PIPE LATERAL.
- ⑤ ELECTRIC WIRES IN 2" SCHEDULE 40 ELECTRICAL CONDUIT FROM CONTROLLER TO VALVE.
- ⑥ 6" UNLESS OTHERWISE NOTED.
- ⑦ 2" FROM BOTTOM OF TRENCH.
- ⑧ SLEEVING - 26" BENEATH PAVING, MINIMUM SIZE: 4" OR AS REQUIRED.
- ⑨ NATIVE SOIL COMPACTED TO 95%.
- ⑩ PVC PIPE MAINLINE.
- ⑪ PAVEMENT SUBGRADE AS PER CITY OF CHICO SPECIFICATIONS.
- ⑫ SIDES OF TRENCH WILL BE DUG SQUARE AND BE CLEAN OF ALL SHARP MATERIAL.

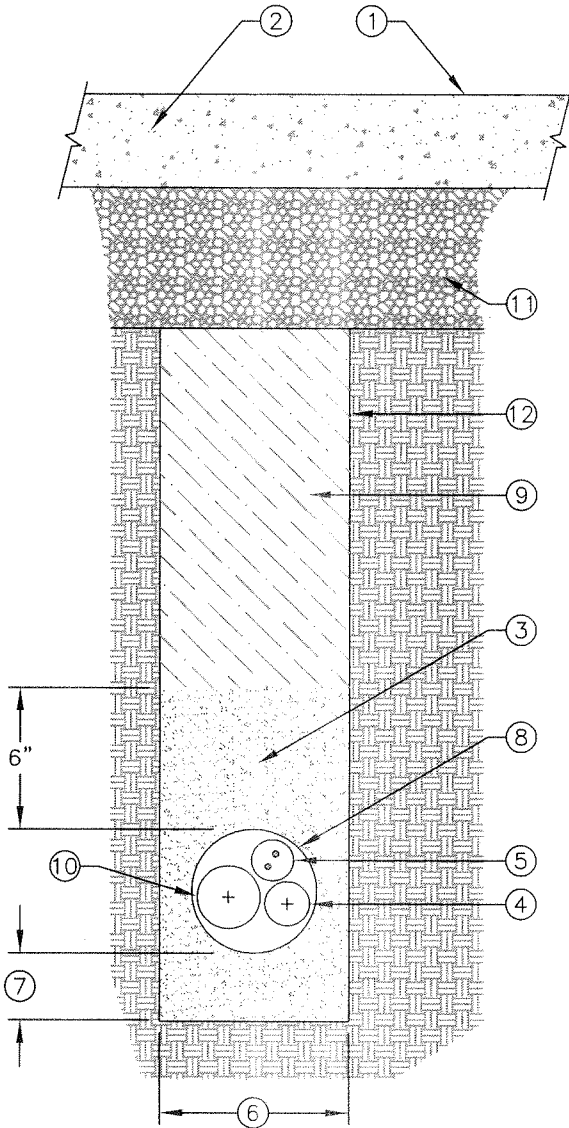

**SECTION VIEW**

REVISION	BY	DATE	APP. BY COUNCIL

**CITY OF CHICO**

**STANDARD PLAN**

DRAWN BY: GL      DATE: 10/06  
 CHECKED BY: DB      SCALE: NONE  
 APPROVED: [Signature]  
 DIRECTOR OF ENGINEERING

**TRENCHING DETAIL  
 BENEATH PAVING  
 (VEHICULAR)**

NO.  
**LS-14**

SHEET 3 OF 3