

*ALL SIDEWALKS MUST COMPLY WITH CURRENT FEDERAL ADA REQUIREMENTS

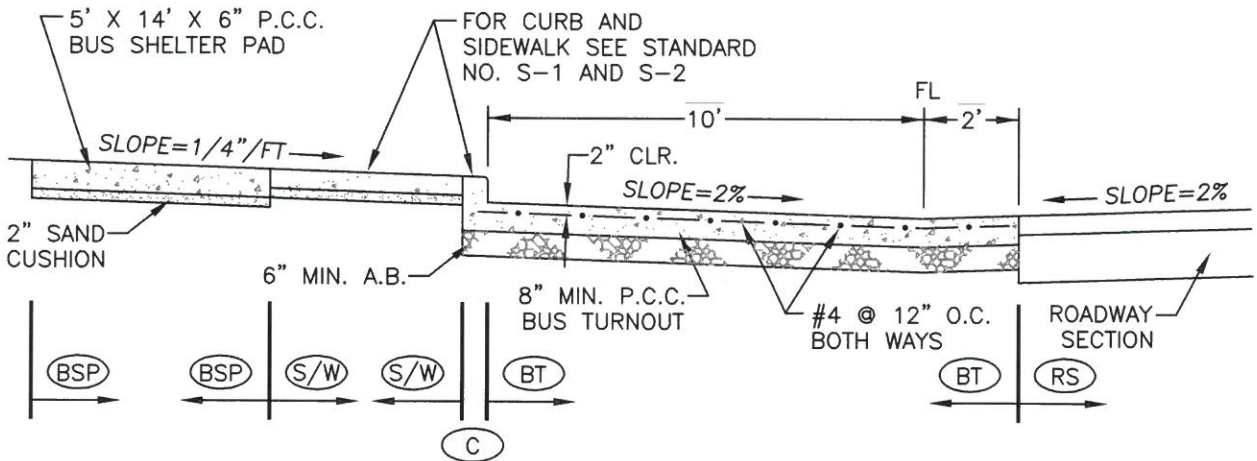
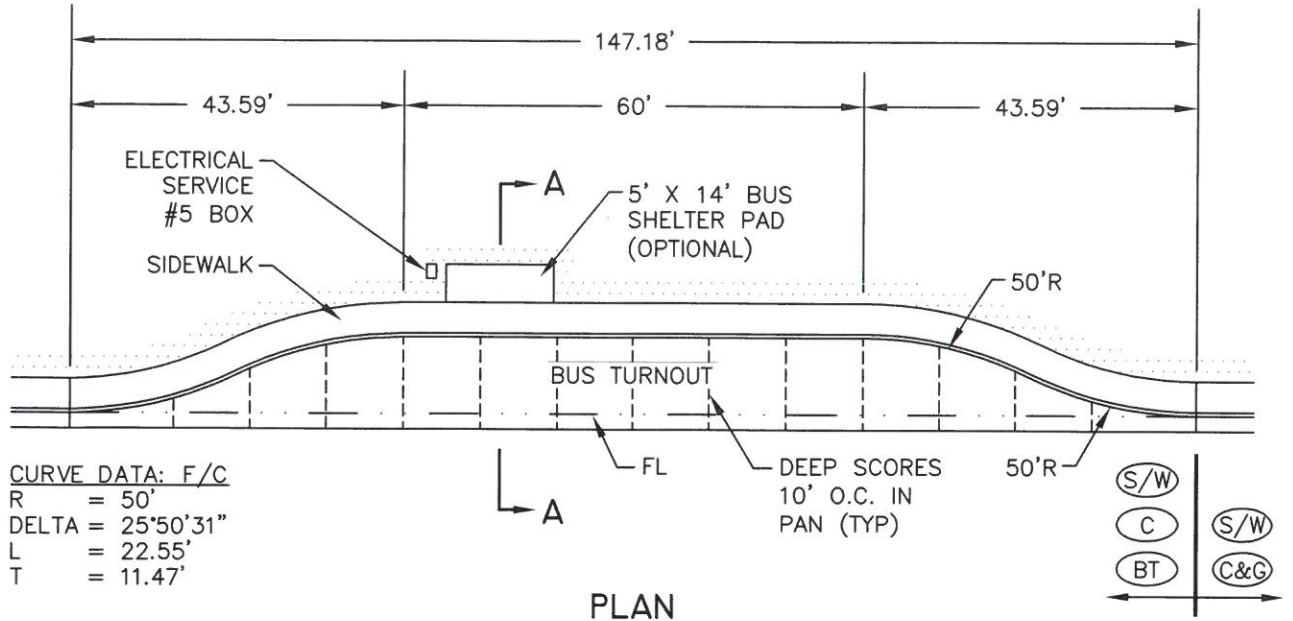

NOTES:

1. FOR EACH ADDITIONAL PASS THROUGH BUS SPACE ADD 50' AND FOR EACH ADDITIONAL LAYOVER BUS SPACE ADD 80'.
2. CONCRETE SHALL BE CLASS A, REBAR STEEL SHALL BE 60 GRADE.
3. STANDARD BUS SHELTER: TOLAR MODEL #13NALD-GL

(BT) = QUANTITY PAYMENT LIMITS FOR CITY CONTRACTS

REVISION	BY	DATE	APP. BY COUNCIL

CITY OF CHICO		STANDARD PLAN	
DRAWN BY: GL	DATE: 02/2016	BUS TURNOUT	NO. S-28
CHECKED BY: BO	SCALE: NONE		SHEET 1 OF 1
APPROVED: <i>Bob Otter</i>	PUBLIC WORKS DIRECTOR-ENGINEERING		