

PLAN

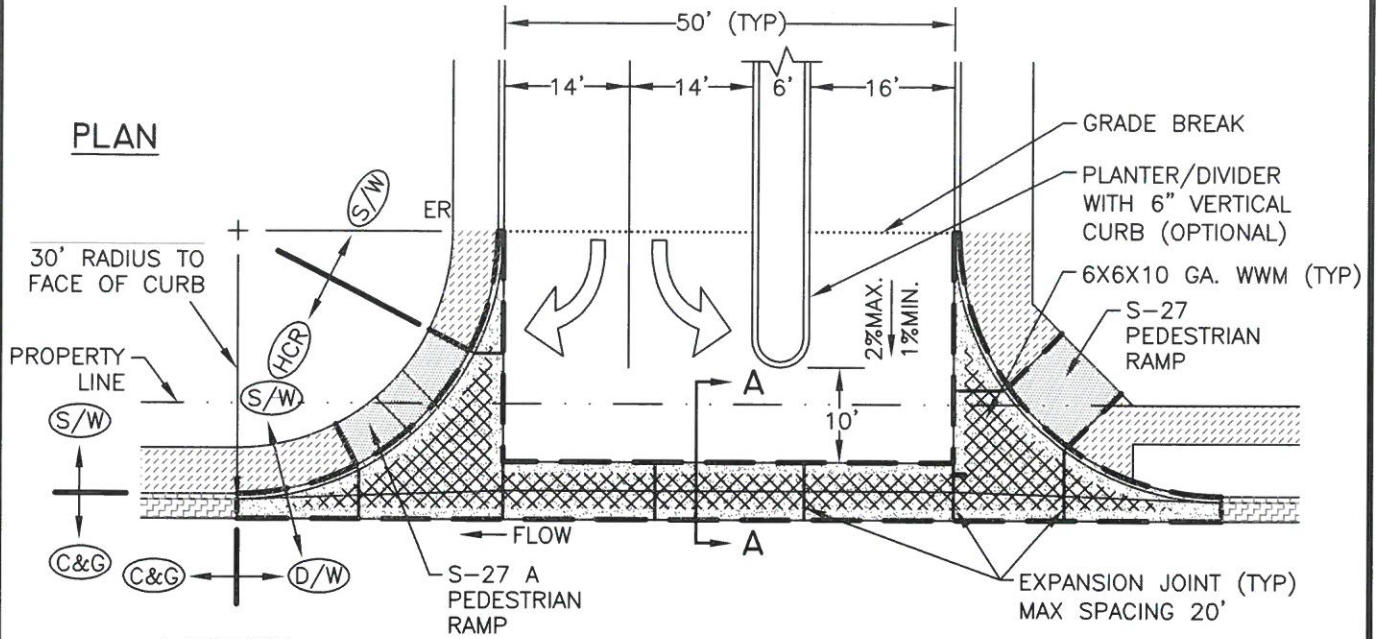

LEGEND

- (D/W) = QUANTITY PAYMENT LIMITS FOR CITY CONTRACTS
- = DRIVEWAY PAYMENT LIMITS
- [Hatched pattern] = 8" P.C.C. D/W, C&G AND VALLEY GUTTER
- [Dotted pattern] = P.C.C. S/W
- [Cross-hatched pattern] = P.C.C. C&G
- [Solid grey pattern] = P.C.C. PEDESTRIAN RAMP

END OF 30' RADIUS CURB RETURN

REINFORCE WITH #4 REBAR 18" ON CENTER, OR WITH 6X6X10 GAUGE WELDED WIRE MESH

SECTION A-A

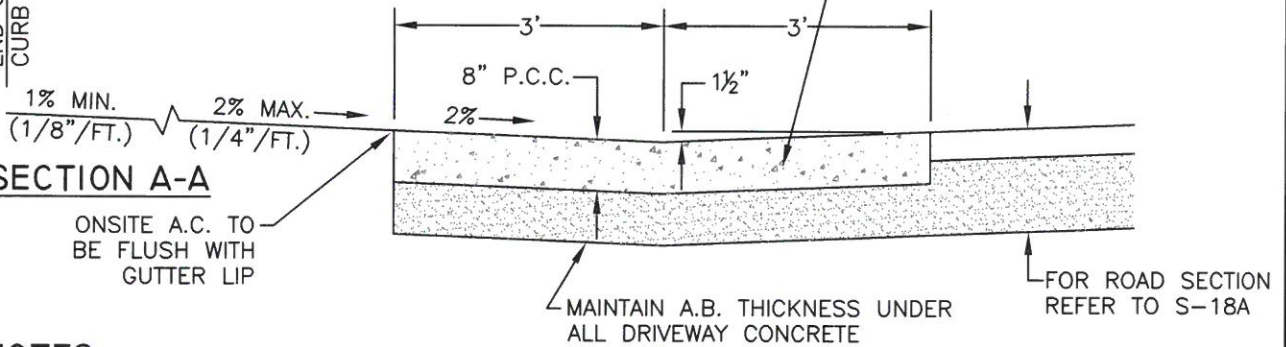

NOTES:

1. STD S-5C SHALL BE USED FOR MAJOR COMMERCIAL, INDUSTRIAL AND RESIDENTIAL DEVELOPMENTS IN ACCORDANCE WITH APPROVED PLANS.
2. DRAINAGE TO VALLEY GUTTER RESTRICTED TO DRIVEWAY AREA WITHIN 30' OF FACE OF CURB.
3. NO INTERIOR PARKING LOT AISLE SHALL INTERSECT THE DRIVEWAY WITHIN 100' OF PROPERTY LINE.
4. LEFT TURN STORAGE LANE LENGTH SHALL BE 75' MINIMUM.
5. THE ONSITE DRIVEWAY LANE CONFIGURATION SHOWN HEREON IS PROVIDED TO ILLUSTRATE TYPICAL CRITERIA TO BE USED WITH THIS INSTALLATION. ACTUAL LANE CONFIGURATION SHALL BE IN ACCORDANCE WITH APPROVED PLANS.

REVISION	BY	DATE	APP. BY	COUNCIL

CITY OF CHICO

STANDARD PLAN

DRAWN BY: GL DATE: 02/2016
 CHECKED BY: BO SCALE: NONE
 APPROVED: [Signature]
 PUBLIC WORKS DIRECTOR-ENGINEERING

**CURBED DRIVEWAY
ENTRANCE**

NO. **S-5C**

SHEET 1 OF 1