

(S/W) = QUANTITY PAYMENT LIMITS FOR CITY CONTRACTS

* MAX. ALGEBRAIC DIFFERENCE OF 17.5%

2" SAND CUSHION

6"

12" #4 DOWELS SPACED AT 18" ON CENTER DRILLED AND EPOXIED INTO EXISTING

SECTION A-A

CURB OR CURB & GUTTER IS EXISTING OR POURED SEPERATELY (COMMERCIAL DRIVEWAY ONLY)

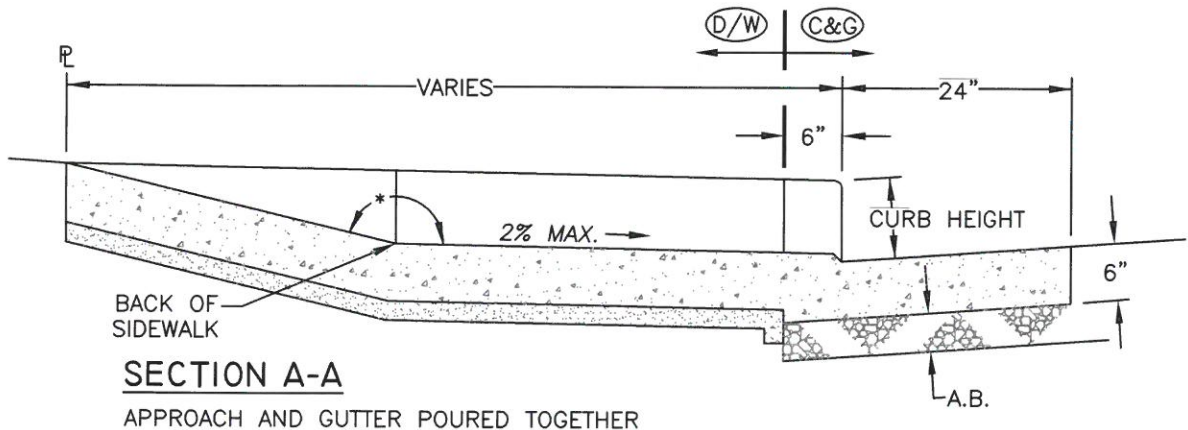

REVISION	BY	DATE	APP. BY	COUNCIL

CITY OF CHICO

STANDARD PLAN

DRAWN BY: GL DATE: 02/2016
 CHECKED BY: BO SCALE: NONE
 APPROVED: [Signature]
 DIRECTOR OF PUBLIC WORKS-ENGINEERING

CURB, GUTTER AND DRIVEWAY DETAILS

NO. **S-5B**

SHEET 1 OF 1