

STANDARD DRIVEWAY

(S/W) = QUANTITY PAYMENT LIMITS FOR CITY CONTRACTS

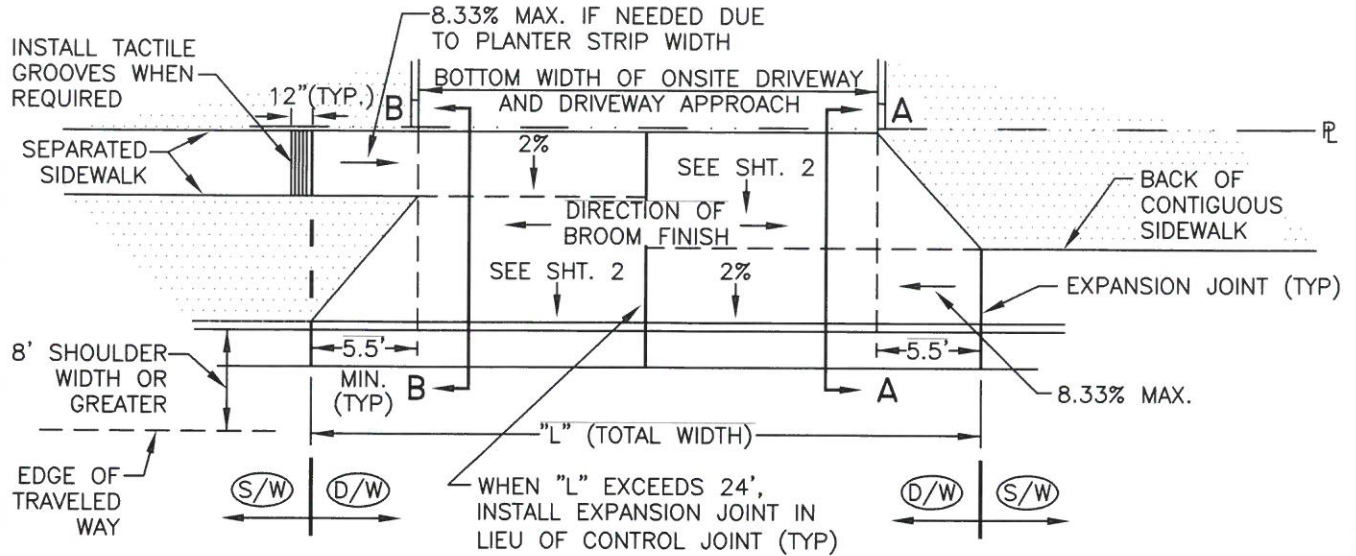

MODIFIED DRIVEWAY

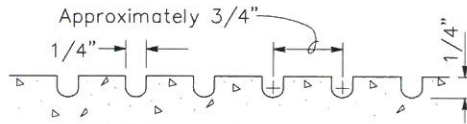
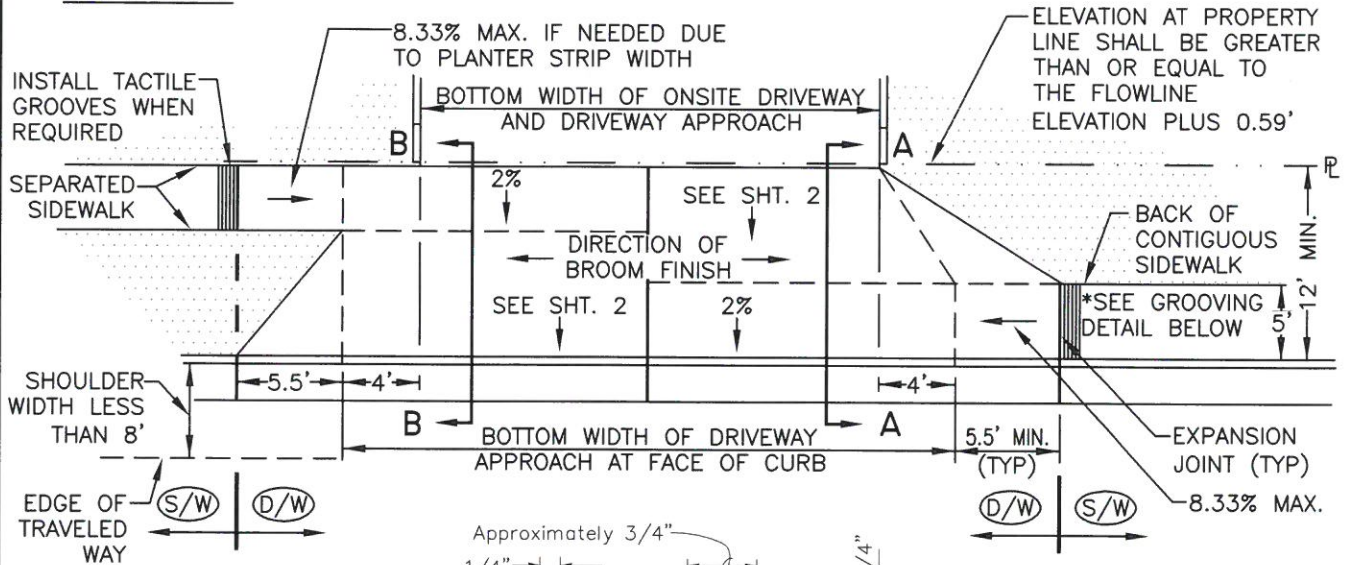

ELEVATION (STD. D/W)

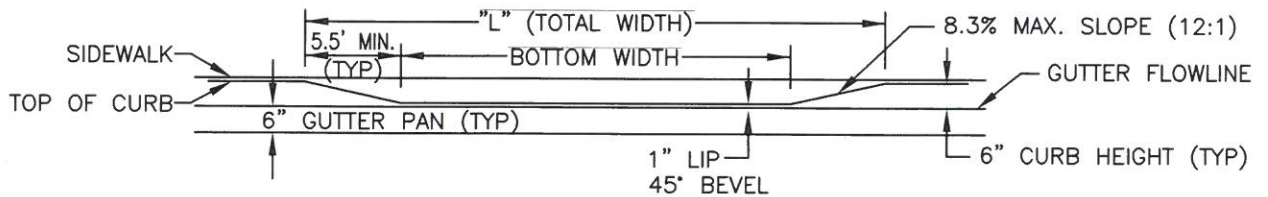

REVISION	BY	DATE	APP. BY

CITY OF CHICO

STANDARD PLAN

DRAWN BY: GL DATE: 02/2016
 CHECKED BY: BO SCALE: NONE
 APPROVED: [Signature]
 PUBLIC WORKS DIRECTOR-ENGINEERING

COMMERCIAL DRIVEWAY APPROACH

NO. S-5A

SHEET 1 OF 2

SECTION A-A

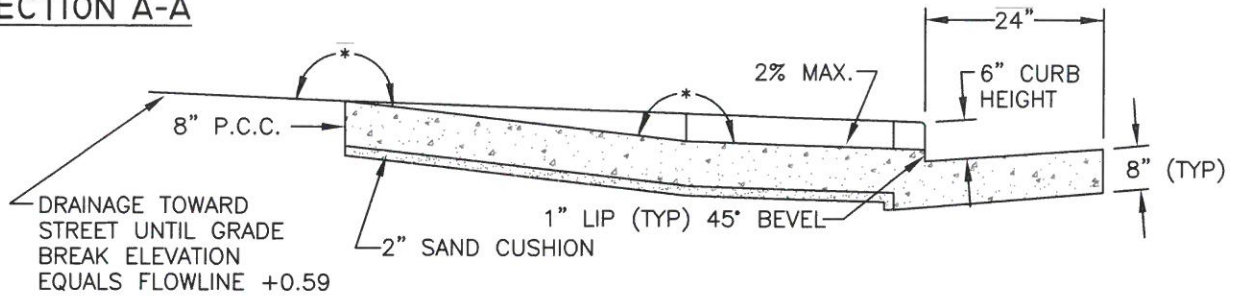

SECTION B-B

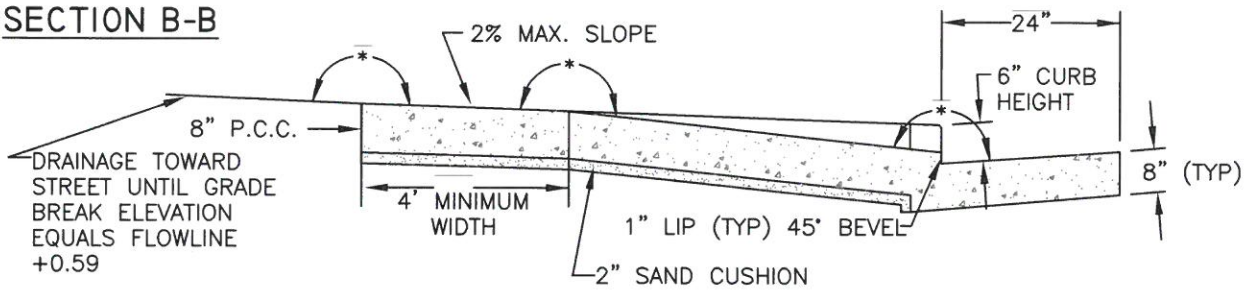

* MAX. ALGEBRAIC DIFFERENCE OF 17.5%

NOTES:

1. STANDARD S-5A SHALL BE USED FOR COMMERCIAL AND INDUSTRIAL DEVELOPMENTS, RESIDENTIAL DEVELOPMENTS WITH GREATER THAN 8 ONSITE PARKING SPACES AND PRIVATE STREET SUBDIVISIONS.
2. MODIFIED DRIVEWAY SHALL BE USED WHERE ROADWAY SHOULDER IS LESS THAN 8'.
3. BOTTOM WIDTH OF STANDARD DRIVEWAY AT FACE OF CURB:
 - A) ONE WAY - 14' MINIMUM, 18' MAXIMUM
 - B) TWO WAY - 24' MINIMUM, 30' MAXIMUM
4. BOTTOM WIDTH OF MODIFIED DRIVEWAY AT FACE OF CURB:
 - A) ONE WAY - 22' MINIMUM, 26' MAXIMUM
 - B) TWO WAY - 32' MINIMUM, 38' MAXIMUM
5. WHEN DRIVEWAY SERVES AS ALLEY APPROACH, REINFORCEMENT REQUIRED WITH 6" SIDEWALK.

REVISION			
BY			
DATE			
APP. BY COUNCIL			

CITY OF CHICO

STANDARD PLAN

DRAWN BY: GL DATE: 02/2016
 CHECKED BY: BO SCALE: NONE
 APPROVED: [Signature]
 PUBLIC WORKS DIRECTOR-ENGINEERING

**COMMERCIAL
DRIVEWAY APPROACH**

NO.
S-5A

SHEET 2 OF 2