

Appendix A
(1 of 4)

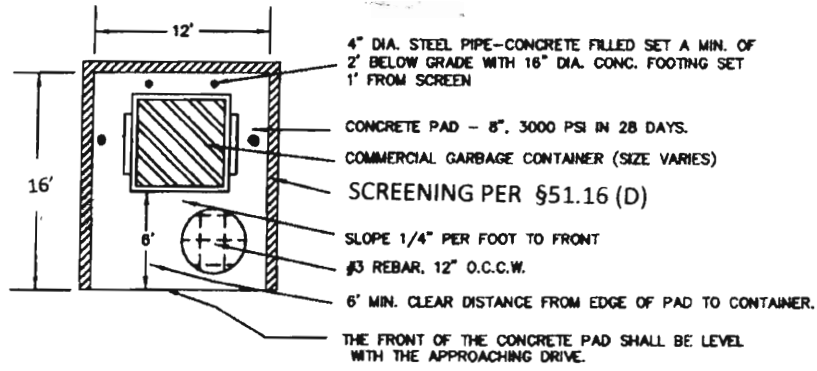

PLAN VIEW

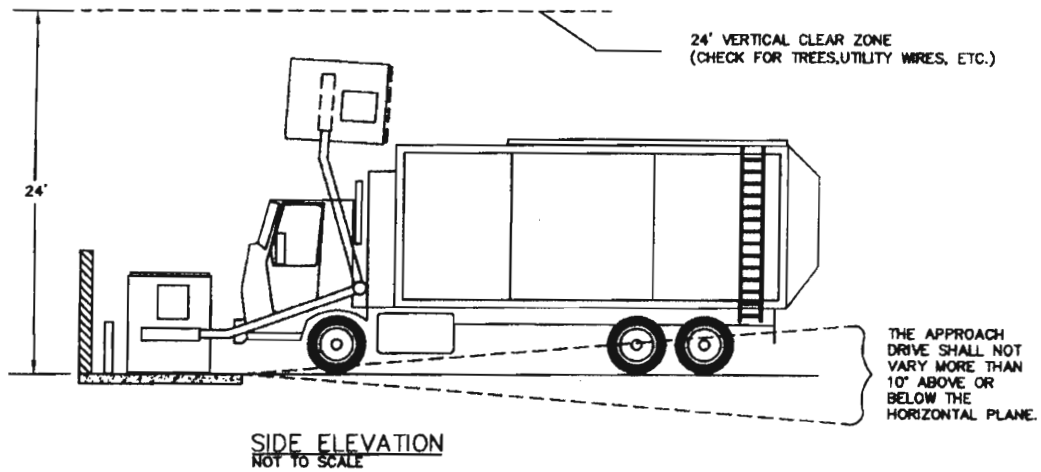

NOTE:
IT SHALL BE THE RESPONSIBILITY OF THE OWNER TO OPEN GATES USED TO ENCLOSED CONTAINERS PRIOR TO COLLECTION.

PROPERTY OWNER/TENANT IS RESPONSIBLE FOR MAINTAINING DUMPSTER ENCLOSURES AND ADEQUATE ACCESS / EGRESS. DUMPSTER PADS MAY NOT BE LOCATED IN RIGHT OF WAY OR FIRE LANES.

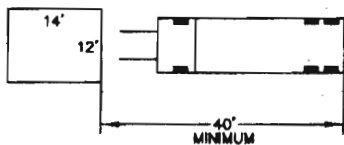

HORIZONTAL CLEAR ZONE FOR TRUCKS APPROACHING A COMMERCIAL GARBAGE SHALL BE A MIN. OF 40' FROM THE FRONT OF THE PAD.

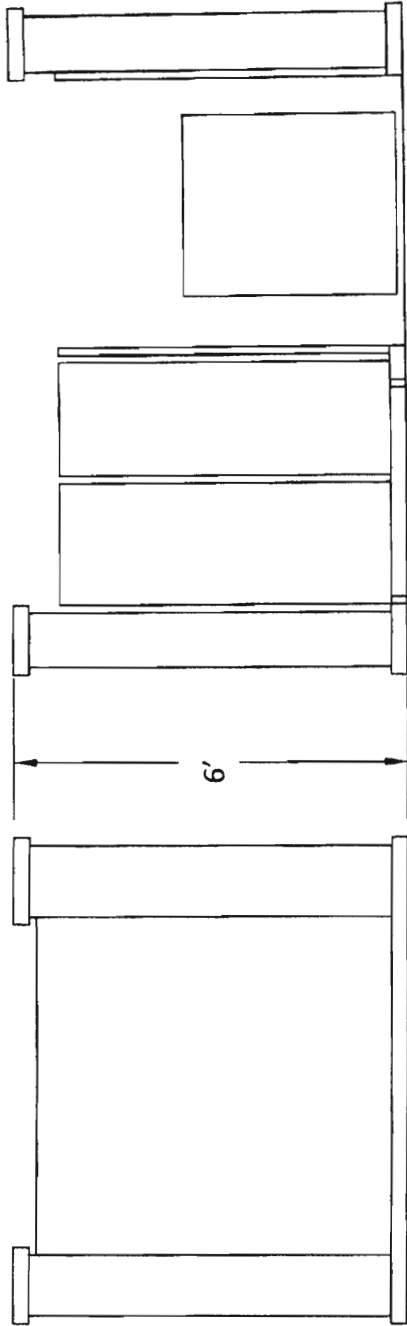

SIDE VIEW

* Min. 6' - Max 8'

PARTIAL FRONT VIEW

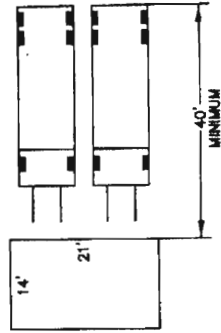

HORIZONTAL CLEAR ZONE FOR TRUCKS APPROACHING A COMMERCIAL GARAGE SHALL BE A MIN. OF 40' FROM THE FRONT OF THE PAD.

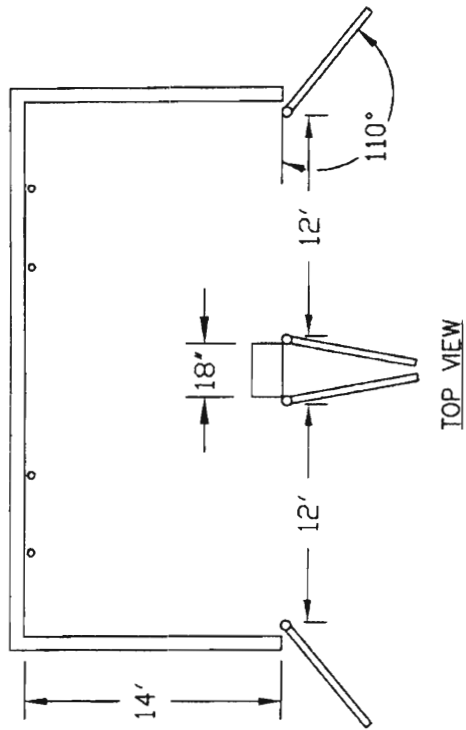

TOP VIEW

Appendix A
(3 of 4)

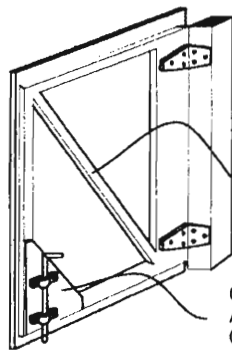
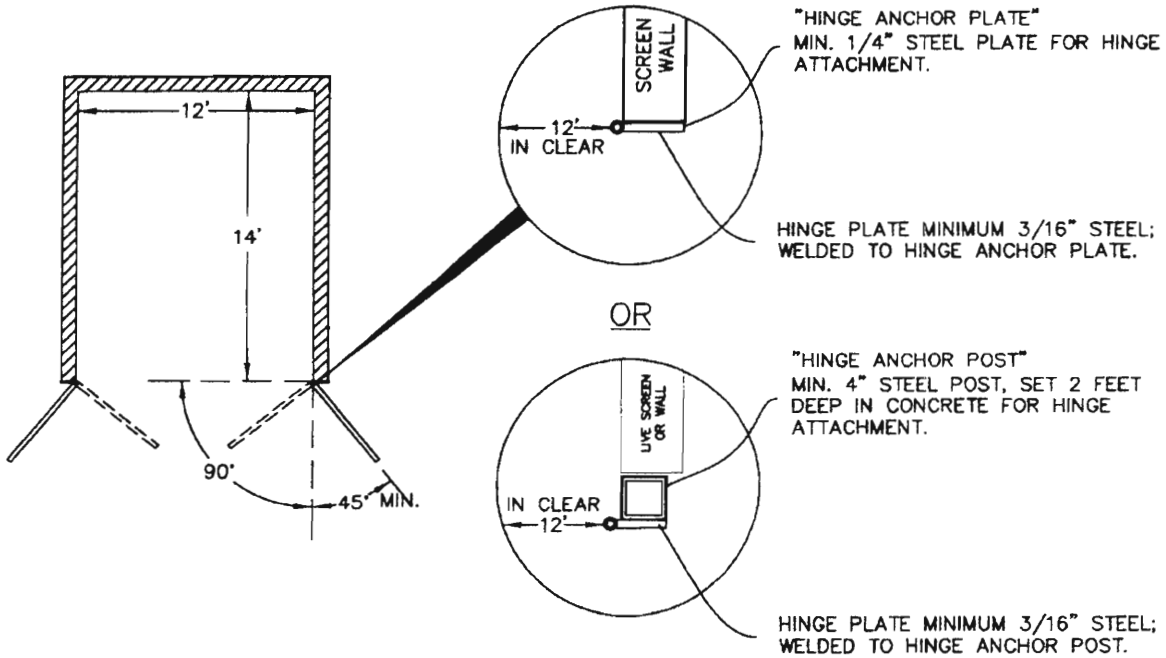

ALL GATES SHALL BE CONSTRUCTED IN MANNER TO INSURE THAT GATE CAN SUPPORT ITS OWN WEIGHT, IN A FREE SWINGING POSITION. METAL DOORS SHALL BE PRIMED AND PAINTED.

ALL GATE SHALL HAVE CROSS MEMBER FOR BRACING.

GATE STOPS MUST BE INSTALLED ON ALL GATES TO SECURE GATE IN OPEN OR CLOSED POSITIONS.

NOTE:
ENCLOSURES CONTAINING MULTIPLE DUMPSTERS;
2-DUMPSTERS W/O CENTER POST FOR GATES
21 FT. GATE OPENING X 14 FT. DEEP

2 OR MORE DUMPSTERS-12 FT. IN CLEAR GATE
OPENINGS W/ CENTER POST X 14 FT. DEEP

Appendix A
(4 of 4)

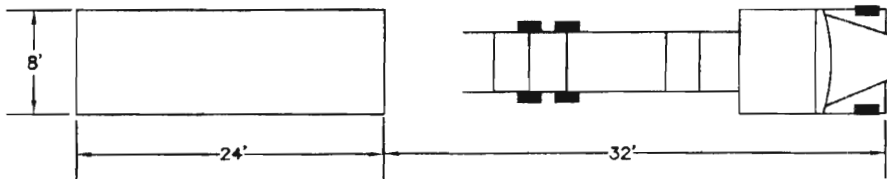
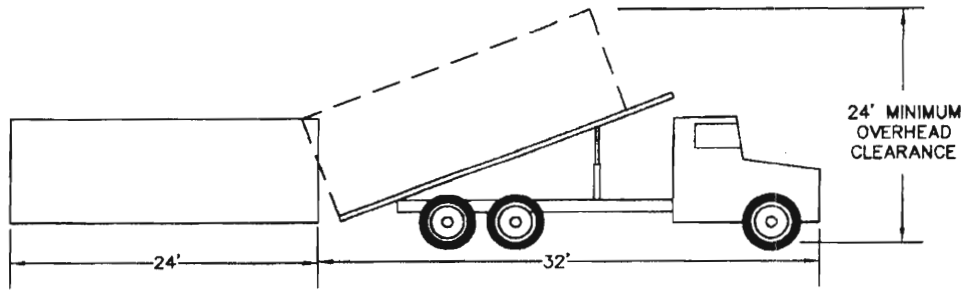

NOTE:
NEED MINIMUM CLEARANCE
12'W X 60'L X 24'H