

PERMANENT REPAIRS

1. CONCRETE STREET

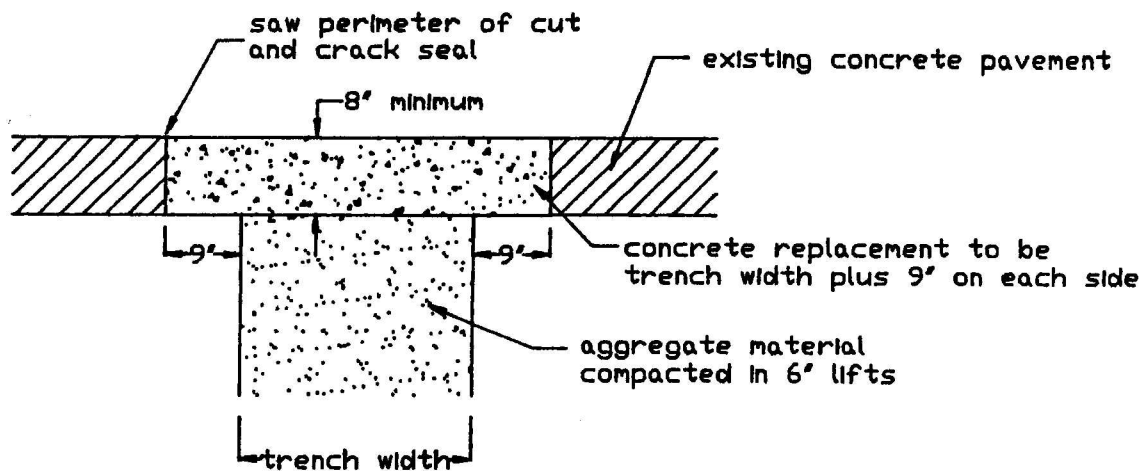

2. RIGID BASE OR FLEXIBLE BASE UNDER ASPHALT SURFACE

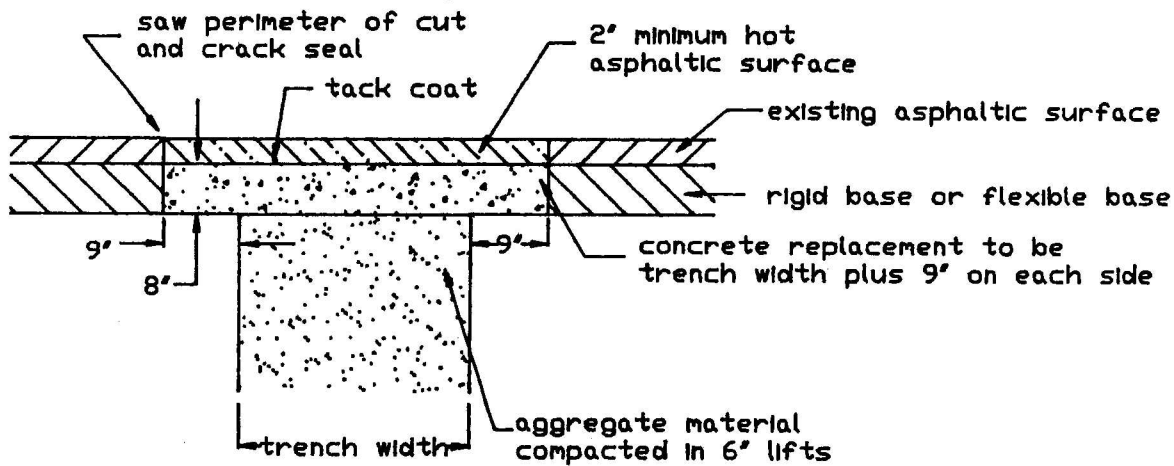

3. BRICK STREET

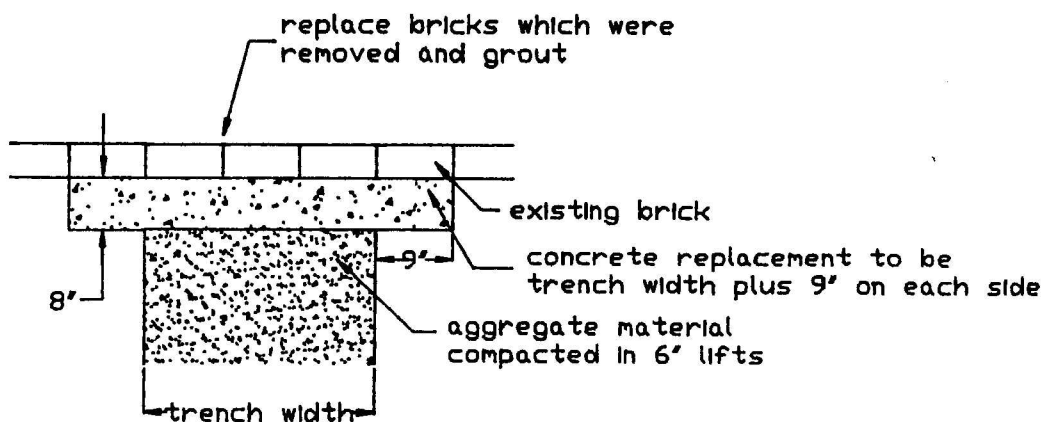

TEMPORARY REPAIR OF ASPHALT OR CONCRETE STREET

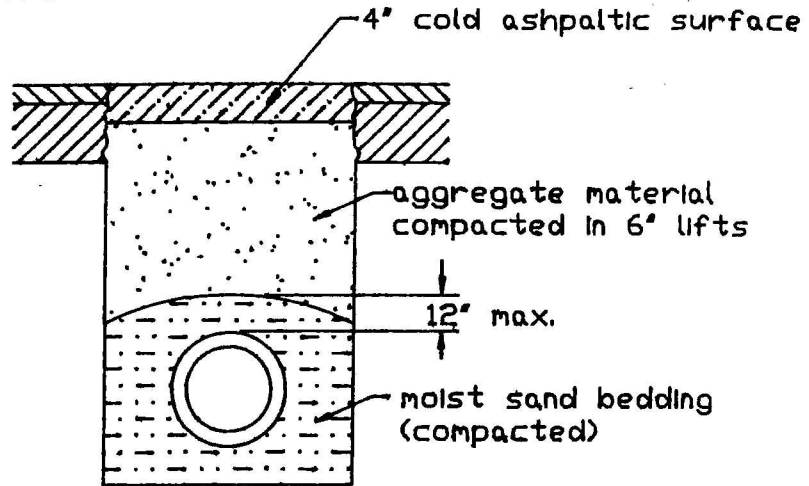

REPAIR OF BARHOLES

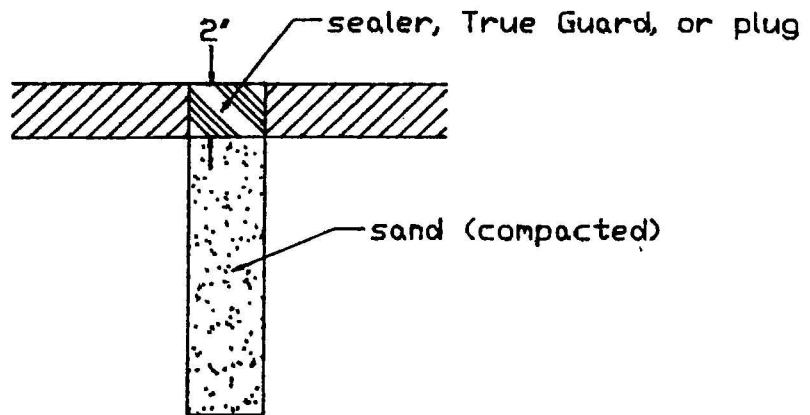

ADJUSTMENT OF MANHOLES

